



Guarantee, Installation and Operating Instructions Luxaflex® Wood Venetian Blinds 25/50/ & 68mm slat widths Standard and Evo'lution headrails

Dear Customer,

We thank you for choosing Luxaflex® products. In the unlikely event that the Luxaflex product guarantee service is needed, please contact the dealer from whom the product was purchased. Alternatively you may contact a member of our authorised Luxaflex® service network. In order to minimise any unnecessary inconvenience, we suggest that the product installation instructions are read carefully before contacting the dealer on our service network.

GUARANTEE

Luxaflex® guarantees that all Luxaflex® window covering products are free from material and assembly defects, provided that such products were properly installed in a domestic situation. For non-domestic installations, refer to the Luxaflex® general sales conditions. The obligation of Luxaflex® is limited to repair or replacement of the defective materials or components. Repairs will be made with like or similar parts. The guarantee is limited to the original purchaser.

Scope of warranty	Year since date of purchase				
	1 yr	2 yrs	3 yrs	4 yrs	5 yrs
Removal of product from end user's window	X	X	X	X	X
Carriage (to - from factory)	✓	X	X	X	X
Labour (assembly / repair)	✓	X	X	X	X
Re-installation of product at end users window	X	X	X	X	X
Components (with like or similar parts)	✓	✓	✓	✓	✓
Cords	✓	✓	✓	X	X
Fabric (with like or similar fabric)	✓	✓	✓	X	X
Consequential loss	X	X	X	X	X

This guarantee is invalid if the damage or failure is caused by:

- Accident • Misuse/Abuse • Alteration • Motorised devices • Exposure to elements
- Normal wear and tear • Blinds that are not fitted in a domestic situation.
- Failure to follow measurement, installation, cleaning and maintenance instructions

The guarantee is exclusive and in lieu of all other obligations, liabilities or warranties. In no event shall Luxaflex be liable or responsible for incidental or consequential damages or for any other direct or indirect damage, loss, cost, expense or fee.

The guarantee does not affect the consumers statutory rights under applicable national laws in force, nor the consumers rights against the dealer arising from their sales/purchase contract.

FITTING

Standard 25 or 50mm Blinds
Standard Brackets

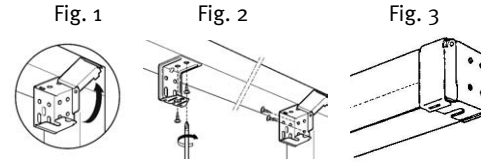

Before fixing your wood blinds, check to ensure that the fixing surface is flat, level and the mounting points are firm enough to take the brackets. Also, ensure that the positions you choose for the brackets will allow the blind to be raised and lowered without obstruction (check window opening handles etc.).

Mark, drill and plug as necessary the positions of the brackets. The box brackets should be fitted at either end of the headrail, so that they are slightly wider apart than the width of the headrail. The brackets can be top, side or face fitted. (Fig. 1)

On wider blinds you will have been supplied with center support brackets (Fig. 2) which can be top or face fitted. These should be equally spaced, while ensuring that they will not coincide with the ladder braid/tapes fitted to your blind.

Open the front "flap" of the box brackets (Fig. 1), slide the headrail of your blind into the brackets (also the center support brackets, where fitted). Lower the flap until it locks into position on the bottom of the bracket (Fig. 3).

SPECIAL INSTRUCTIONS FOR 68mm SLAT

With a 68mm slatted blind, the slats will overhang the headrail when the blind is raised. Therefore if top fixing, a minimum gap of 12mm (1/2") must be left between the back of the bracket and the wall (Fig. 4).

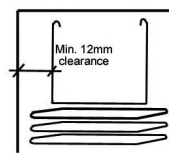

Fig. 4

The extension brackets supplied should be used if face fixing.

Fit the extension bracket to the wall, spacing them approximately 5mm (1/4") further apart at each end, than the width of the headrail. Attach the standard brackets to the extension brackets with the self tap screws supplied, ensuring that they are fitted to the relevant holes that will give a minimum clearance of 12mm (1/2") clearance to the back of the headrail (Fig. 5).

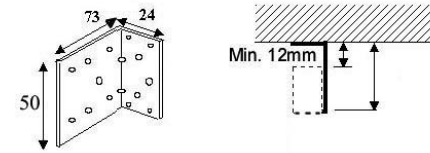

Fig. 5

Valance

Metal clips have been pre-fitted to the back of the valance. Additional headrail clips have been supplied which require mounting on to the front of the headrail of your blind as in fig 1.

Align the position of the headrail clips with those on the valance and 'click' the valance in place as shown in fig 2. The valance should now be locked in place and ready for use.

The valance can easily be removed by using a flat head screwdriver. Slide the screwdriver up behind the valance until it hits the bracket. Lever the screwdriver away from the blind at the bottom. This should release the valance from the brackets, see fig 3.

If you have ordered mitred returns, these should be glued together, with glue supplied, prior to fitting the blind. Wetting slightly the surfaces being attached together can improve the adhesion.

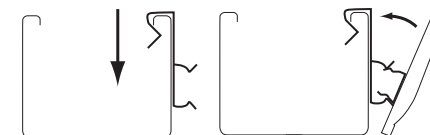

Fig. 1

Fig. 2

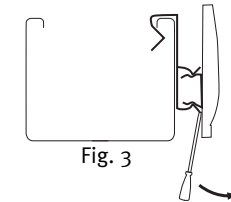

Fig. 3

YOUR BLIND IS NOW READY FOR OPERATION.

OPTIONS

Swivel Brackets (if specified)

(Should not be used with 50mm Electric operated blinds)

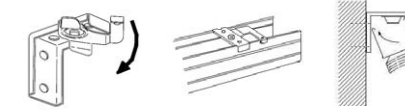

The brackets provided should be installed approximately 75mm (3") from the ends of the blind, they can be top or face fixed. The remaining brackets should be equally spaced up to a maximum distance of 1500mm (59") apart. Always look in the top of the head rail, to check that the positions chosen for the brackets will not affect any of the internal mechanisms. Ensure the swivel part of the bracket is in the open position and then offer the blind into the brackets as shown above. Push the swivel arms closed to lock the blind in place.

Extension brackets

Standard brackets can be attached to two sizes of extension brackets to give additional clearance, as required.

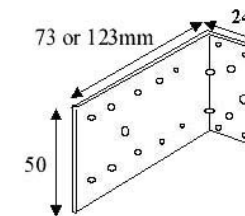
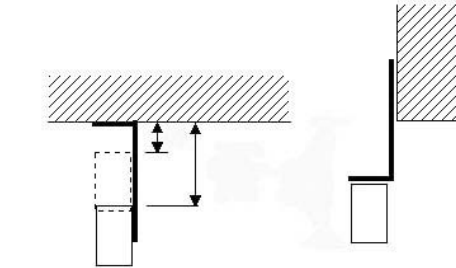

Side Guiding

Your blind will come with the guide cables pre-fitted in the headrail. When the blind has been fitted, lower the blind and pull the cables down tight. Mark the positions where you will mount the brackets. Screw the bracket into place (either face or sill as specified with order). Ensure cables are mounted vertically or they could restrict the fall of the blind. Locate the lower locking ring onto the cable, tighten the grub screw onto the cable in the correct position, so that the locking ring locates under the brackets.

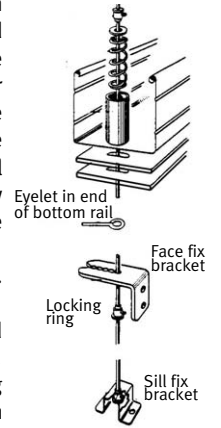

Hold Down Brackets

To fit hold down brackets, lower the blind fully. Locate the brackets onto the pins in the bottom rail. Mark the hole positions and screw brackets into place. There are two types of bracket available, a face/sill bracket or a side fix bracket.

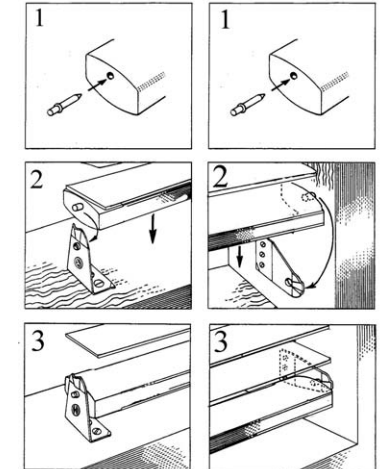

**Evo'lution Wooden Venetian Blinds
50mm slat width**

HOW THE BRACKETS WORK

Sufficient brackets are enclosed to ensure secure fixing of your new wood blind. When fitted, the brackets support the headrail and can be either face or top fixed. (Fig. 1)

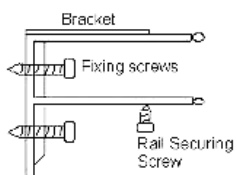

Fig 1

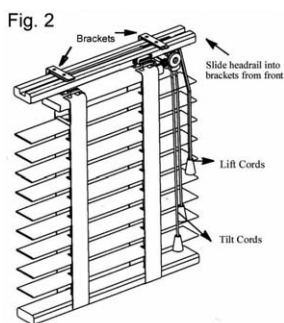

Fig. 2

HOW TO INSTALL

Before fixing your blind, check to ensure the fixing surface is flat and level and that the mounting positions are firm enough to take the brackets. You should ensure that the positions you choose for the brackets will allow the blind to drop freely, clearing any obstructions such as window handles, etc. (Fig. 2)

Mark the positions of the end brackets at 100mm (4") in from each end of the headrail. Make sure the bracket positions do not obstruct the operating mechanisms.

Mark, drill (plug if necessary) and fit any intermediate brackets supplied. These should be equally spaced between the end brackets but check that the proposed fitting positions will not interfere with the mechanisms on the headrail. Slide the blind headrail backwards into the brackets until it hits the back of the brackets.

Centralise the blind within the brackets to make sure there is the same clearance on either side of the slats. Secure the headrail in place by screwing through the underside of the bracket into the headrail, this should be done on all brackets supplied (Fig. 3).

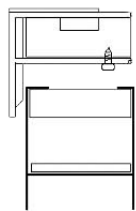

Fig 3

YOUR NEW BLIND IS NOW READY TO OPERATE.

HOW TO OPERATE YOUR BLIND

To raise

Pull lift cords straight down, when in desired position the cord- lock will engage to hold the blind in position.

To lower

Move lift cords towards the centre of the blind. Gently tug the cord to release safety cord-lock, relax your grip and allow the cord to slide slowly through your hand. To stop the blind at the desired height, simply move the cord back to its original vertical position.

To tilt slats

Holding one tilt cord in each hand to maintain friction on tilt gearbox, pull the relevant cord to tilt the slats to the desired position.

Equaliser

There is a small buckle on the pull cords. The cords can be fed through this to adjust the level of your blind.

CLEANING

Blinds can be kept clean by regular dusting with a soft cloth. A high- grade wood polish will enhance and maintain the natural grain of the wood.

HOW TO REMOVE YOUR BLIND

Box brackets

Press up on the underside of the bracket, whilst pulling flap on front. This will release the flap from its locked position. When both brackets are opened the blind can be slid forward from its brackets.

Swivel brackets

Pull swivel arm locks away from the headrail to release blind, leaving the central brackets until last. A flat blade screwdriver can be used to open the swivel arm locks, taking care not to damage the rail.

Evo'lution brackets

Remove the rail securing screws from the underside of the brackets then slide headrail forward.

Wood Characteristics

The beauty of wood lies in a variety of natural elements consisting of distinctive grain patterns, natural colour variations and distinguished markings. These elements serve to confirm the authenticity of the wood.

What to look for when you purchase wood blinds.

The following terms describe some of the more common characteristics you will find in all wood products and wood blinds.

Grain

The direction and regularity of the wood fibres – varies widely depending on where it was cut from within the tree. The type, direction and density of the grain produce the unique patterns and colour variations that make each piece of wood distinctive.

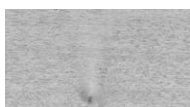
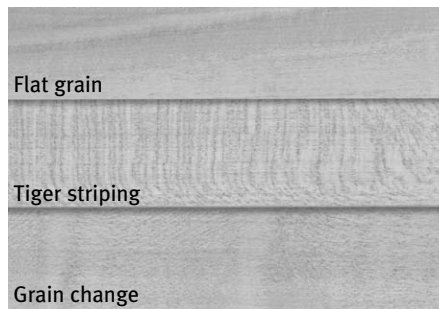

Pin knots
The remnants of branches encased by the growth of new wood.



Burl figures
Formed by irregular growth on the outer surface of the tree.



Mineral deposits
Usually the result of environmental circumstances affecting the development of the tree.



window styling

HunterDouglas Ltd. Window Fashion Division
Mersey Ind. Est., Heaton Mersey, Stockport, Cheshire SK4 3EQ.
Tel: 0161-442 9500 Fax: 0161-432 3200.

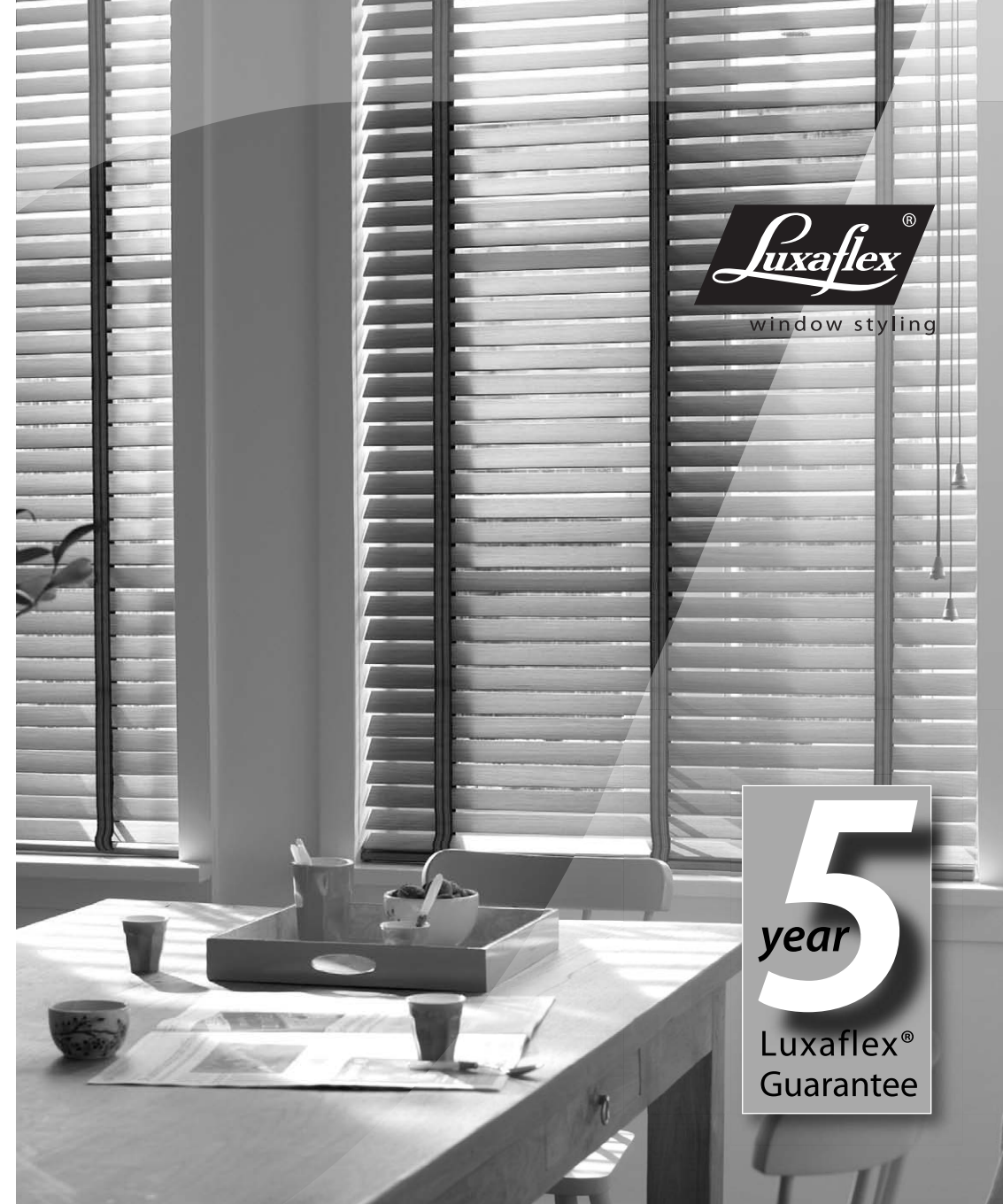

5
year
Luxaflex®
Guarantee

Guarantee, Installation and Operating Instructions

Luxaflex® Wood Venetian Blinds